



**OPERATION AND ASSEMBLY MANUAL
OF CENTRIFUGAL FANS TYPE MSB**

INTRODUCTION

This manual covers fan listed on frontpage. It is source of information necessary for safe and proper use. Read this manual carefully before any use of the device, comply with it requirements and keep it in place with easy access for users and service. If case of any doubts about use of the fan, please contact with manufacturer.

Additional requirements about use of the unit can be found in electric motor documentation and markings - those requirements need to be met.



After receiving the device - check

- whether the device is in compliance with order,
- whether the data on the rating plate are the same as desired.
- whether fan was not damaged during transport (e.g. there are no dents/cracks)
- whether a motor documentation (containing manual) is attached

In case of any irregularities, contact with your dealer or Venture Industries Sp. z o.o. service.

1. GENERAL INFORMATION

1.1 Information about device

- The fan is a not completed machine within the meaning of the Machinery Directive 2006/42/WE (please refer to the manufacturer's declaration – Appendix D).
- Fan is designed for use by trained, qualified adult persons in industrial environment. The fan is not designed for household or similar use.
- The device is designed to transport clean air and air with dust - required contact with manufacturer. **Do not transport the explosive mixtures**, solid elements, liquids, **substances that cause abrasion**, chemically reactive compounds. Minimal temperature of transported medium is -20°C, maximum is determined on rating plate.
- The fan must be protected from the weather (e.g. snow, rain, excessive sun radiation, lightning). The device is not designed to be installed outdoor. The fan surrounding cannot contain **explosive atmospheres**, substances causing abrasion, chemically aggressive substances, viscous substances, liquid, substances with high humidity. Maximum ambient temperature is determined on rating plate, minimum is -15°C.
- The device must not be exposed to radiation (such as microwave, UV, laser, x-ray).
- The impeller has been balanced in accordance with minimum G6.3 class ISO 1940-1, and general construction of the fan in accordance with cat. BV-3 ISO 14694
- Description of construction of the fan has been included in Appendix E.
- Additional information of the fan usage has been indicated on the device. Additional information have been included in Appendix A.

1.2 General risk and guidelines

During entire fan life cycle pay particular attention to the **risk and guidelines** presented below:

1.2.1 moveable components

- The fan is equipped with moveable components (impeller of the device, impeller of the motor). Contact with them may cause serious injury or death. The fan must not be used if covers (grids) and safety measures against contact with rotating parts have not been installed.



1.2.2 suction

- The fan has high suction power. Clothing, hair, foreign particles, and even body elements can be easily sucked in. It is forbidden to approach the fan in "loose" clothing or reaching toward inlet of working fan and motor impeller. It need to be ensured, that no foreign body can be sucked in.

1.2.3 thrown elements

- The air at the outlet of the fan has high energy. Elements sucked or placed inside the fan can be thrown with a high speed. The fan has stable, solid construction, but as a result of damage or improper use some parts (elements with high kinetic energy) may be thrown away. Make sure that before start and during operation of the fan there are no elements, that may be sucked in (pay special attention to fan inlet side) and there are no person in stream of transported medium (on inlet and outlet side). Do not approach in the immediate surrounding of motor impeller. Do not use fan without proper inlet, outlet and moveable elements covers (grids).

- Unit is not made as gas-tight.

1.2.4 sharp edges

- During manufacturing the fan sharp edges was grinded. However the fan may have edges touching which may cause injury. We recommend the use of relevant protective gloves.



1.2.5. inertness

- The fan has a high inertness. In case of no permanent fix turning on the fan will lead to it uncontrolled movement. The unit can be turn on only after proper installation.

1.2.6 noise

- The sound pressure level is dependent on the operation point. Check the sound pressure level and if necessary use silencers and/or individual protection measures for personnel.

1.2.7 materials

- In case of fire or transport of improper medium – fan parts can generate fumes hazardous to health.

1.2.8. environment

- The fan can make over and under pressure. In areas where a specified air pressure and the quantity of air are required (e.g. in places with combustion) make sure that there would be no deficit/excess of air.

1.2.9 temperature (hot surfaces)

•The housing and fan elements take the temperature of transported medium. During work (e.g. as a result of compression process) the temperature of medium, housing and fan components increase. Electric motor heat up to high temperatures (especially when overloaded/overheated). The appropriate steps need to be made to prevent from fire and burns caused of high temperatures. **In case of fire – to extinguish a fire use fire extinguisher approved for electrical equipment and follow recommendation of fire department.**



1.2.10 unexpected start / connecting power supply

•Before undertaking any kind of work on fan (e.g. installation, maintenance and inspection, disassembly), it has to be completely and reliably disconnected (isolated) from power supply (check there is no voltage). It has to be ensured, that power supply will not be connected during work on fan and moveable parts are not moving.



•Capacitor (only single phase fans) is still energized for certain period of time after turning off the power supply.

•The appropriate steps need to be made in order to provide protection against electric shock and to prevent from access to electrical components by unauthorized person.

•Fan is not equipped with control system – the connecting of power supply causes immediate start-up. The device is not equipped with system, that would permanently shut it down in case of temporary power supply loss. It has to be ensured, that any dangerous or unpermitted event does not occur in case of temporary loss of power supply.



•Thermal sensors installed in motor (if fitted) after tripping caused by motor overheat turn back to initial state after cooling down. It has to be ensured, that any dangerous or unpermitted event does not occur in case of action of thermal sensors and after motor cooling down.

•In case of impeller jamming – its unblocking may cause sudden movement. Appropriate steps need to be made in order to avoid impeller jamming. In case of impeller jamming, fan need to be completely disconnected from power supply and repaired.

•After disconnecting from power supply fan still works for certain time (moveable parts are moving) as a result of energy accumulation.

1.2.11 use

•Improper installation and/or use may lead to damage of the device and occurrence of dangerous situation. The unit can be installed, maintained, dismantled and used only by qualified and authorized personnel, in accordance to safety rules and current regulations in the country of use (including proper electrical authorization). Personnel need to be familiar with reactions caused by the fan.

•**Using of fan in dismantled/uncompleted state is forbidden, e.g. without junction box cover.**

•During the works (e.g. maintenance, installation) the fans surrounding need to be protected from bystanders approach.

•Any modifications of the unit are forbidden. Complicated maintenance work (such as dismantling the motor or impeller) need to be made by Venture Industries Sp. z o.o. service or with it permission - according to additional guidance. Improper assembly may lead to reduce the fan parameters, damage the unit and lead to the dangerous situation.

1.2.12 Accumulation of dust

•Prevent the accumulation of dust, sediment on and inside the fan. Dirt accumulated on: grids – reduce the fan parameters; impeller – may lose it balance; housing and motor – can reduce the cooling; hot surfaces (see 1.2.9) – may ignite.

1.2.13 explosive atmospheres

•Contact of the fan with explosive atmospheres cause in ignition. It is forbidden to contact the fan with explosive atmospheres.



2. TRANSPORT AND STORAGE

2.1 transport and storage guidelines

•The fan need to be transported and stored in original packaging, without excessive shocks. The device must be protected from weather conditions, transported and stored in dry, well ventilated, and free from substances harmful to the device areas. The fan cannot be transported and stored in areas with fertilizers, chlorinated lime, acids and other aggressive chemicals. Fan need to be protected against foreign body entrance.

•Protect the fan against damage (including crush). After lifting unit it need to be put slowly.

•Do not lift the unit by motor elements (e.g. eye bolt), impeller, protection net. **During lifting the device must remain stable.**

•Do not approach lifted device. In case of breaking, falling device may cause serious injury or death.



•It is recommended that storage time does not exceed one year. After long storage, before installation check the fan. (section 5).

3. ASSEMBLY AND INSTALLATION

3.1 General information

•During installation follow the guidelines contained in section 1.2

•The fan is a machine not ready for use (within the meaning of the Machinery Directive 2006/42/WE - before use of the device ensure conformity with requirements of Machinery Directive 2006/42/WE. After installation the device must meet the requirements included in EN ISO 12100, EN ISO 13857, EN ISO 13850 and EN 60204-1 standards. Additional information is included in Manufacturer Declaration (Appendix D).

•Before installation remove temporary items that protect fan during transport and storage (e.g. box, foil, inlet and outlet caps – do not remove any guards) – Starting the fan with those items could lead to damage of the fan. Make sure that the fan is not damaged.

- Ensure that there are no foreign bodies (e.g. mounting elements, tools) inside fan and near of the unit, the fan is properly secured after installation (the cover of connection box is closed and secured, the connecting elements are properly tightened). Technical acceptance need to be carried out in accordance with Appendix B.

During mechanical connection special attention need to be paid to prevent from falling sold objects into fan, which would lead to it damage.



3.2 Assembly information

- Fan need to be mounted in position presented on Fig1., in horizontal motor shaft position, with base (A) on bottom (Note: depending on model - fan outlet position may be different than on diagram). All holes placed in the base have to be used. Ventilation installation need to be connected to fan inlet and/or outlet flange (all holes placed in flange need to be used). For mounting - fasteners secured from loosening need to be used.

Fig. 1

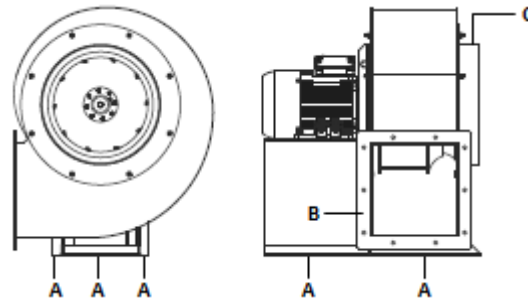

Where:
A - base
B - outlet flange
C - inlet flange

- Supporting construction has to be solid enough in order to carry the weight of the fan and generated vibration (including fan damage). The fan cannot be exposed to vibration.
- Inlet and outlet covers need to be applied. Covers need to protect from touching the impeller according to ISO 13857.
- Fan need to be secured from sucking foreign elements (see paragraph 1.2.3). Inlet and outlet covers must comply with IP20 (EN 60529). If there is still risk of sucking foreign objects - additional protection need to be used.
- It is recommended to apply measures minimizing transmission of vibration from/to the fan. For fans mounted in flexible form - connecting on inlet and outlet side need to be also made in flexible form.
- Keep safe distance between installed device and inflammable elements (special attention to hot surfaces of device need to be paid).
- Keep safe distance between motor cooling impeller and obstacles (in accordance with motor documentation, but not less than on Fig. 2).

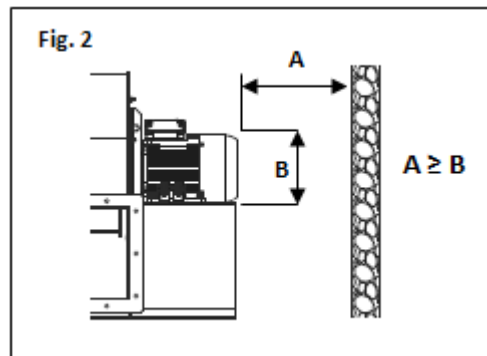

- Measures protecting user from burn by hot elements need to be applied.

3.3 Electrical connection guidelines

- The fan and power supply network must be protected in accordance with local law requirements.
- Detailed guidelines related to electrical connection are located in motor operation manual and on motor markings - those guidelines need to be applied.
- Protection against short-circuits, protection against overload and voltage asymmetry need to be applied. It is necessary to use switch that completely disconnect fan from voltage.
- Use appropriate protection against electric shock. Fan need to be connected to grounding system with designed for such purpose ground terminal (terminals) – according to documentation and markings placed on motor and markings placed on fan.
- Grounding protective terminal (PE) located in motor connection box need be used.
- Voltage and frequency of supply network cannot exceed those indicated on the fan nameplate.
- Use electrical wires with proper insulation and cross-section. Wires need to withstand temperatures that may occur (see 1.2.9). Wires need to be placed in way excluding contact with moving elements and in a way that liquid (e.g. from condensation) does not run over them in the connection box. Cable glands need to be properly tightened.

- Some of fan models are equipped with bimetalic sensor(s) (located in DE bearing shield). Ends of sensors are placed inside motor connection box. During normal operation the sensor circuit is closed (0Ω resistance), and in case of too high temperature - the sensor circuit is open. Ends of sensors need to be connected to proper system (eg. contractor, relay), which shuts down power supply in case of opening sensor circuit.
- Some of fan models are equipped with PTC sensors (located on motor windings). Ends of sensors are placed inside motor connection box. PTC sensor resistance grows rapidly with exceeding of permitted motor temperature value. Ends of sensor(s) placed inside connection box need to be connected to system (eg. relay), which shuts down power supply in case of exceeding permitted motor temperature.

3.4 Impeller rotation direction

Make sure that after installation and during using the fan the impeller would rotate in correct direction. After mounting fan to proper construction, with special care taken and in accordance with sector 1 and 4, launch the fan in impulse way (less than 1 second) and check, if the impeller rotates in correct direction, generating airflow in proper direction (rotation direction need to be checked by checking the motor cooling impeller rotation direction). The work with impeller rotating in the wrong direction reduces fan parameters and may damage it. In case of improper impeller rotation, turn of power supply, wait until impeller stops and change proper power supplying wires in junction box.

4. USE

4.1 Use guidelines

- Make sure that turning on of the fan does not make any hazard for personnel and property. Follow the guidelines featured in section 1.2.
- The fan is designed for continuous operations (S1) – too high frequency of starting a fan may lead to motor overheat and damage.
- Fan cannot work with voltage, frequency, current higher than shown on the fan nameplate** (even if motor nameplate/manual allows it). Applying of higher frequency may cause motor damage or mechanical damage of the fan.
- Use of fan with lowered voltage is not allowed** - it may cause e.g. lack of fan start-up and motor overheating and damage.
- The device cannot work with current consumption exceeding the value indicated on the nameplate.
- In case of activation of any electrical protection, detection of damage, unit must by immediately turn out off use.
- The device is adapted to work in certain range of characteristic. Too high volume flow rate of medium, start/work of device with completely opened inlet and/or outlet may lead to motor overheat caused by current consumption exceeding value on the rating plate (current consumed by fan grows as resistance of installation decreases)
- Units work parameters (temperature of medium, ambient temperature, min and max flow rate....) refer to rated speed.

5. MAINTENANCE, REVIEW

5.1 Maintenance guidelines

- During maintenance and review follow the guidelines contained in point 1.2
- Fan need to be subject of regular review and maintenance (point 5.2).
- Maintenance and review of motor need to be overtaken in accordance with motor documentation and markings.** Exchange of motor bearings need to be made before the end of current bearing lifetime.
- To clean fan construction use slightly damp delicate material. It is prohibited to use detergents, liquids under pressure and tools that may scratch the unit surface.
- The fan need to be turned on at least once a month (minimum couple of impeller turns).
- Ensure that there are no foreign bodies (e.g. assembly components, tools) near and inside the fan inled and outlet channel, the unit is clean, dry and secured after maintenance and review. After cleaning finishes, turn on the fan at max speed for 30 minutes.



- During review special attention to the following need to be paid:

dust and dirt	Prevent the accumulation of dust/dirt on and inside the fan. Dirt accumulated on: grids – may reduce the fan parameters; housing and motor – can reduce the cooling; hot surfaces –may ignite. Special attention must be paid to motor cooling impeller and its cover. Reduction of cooling ability may lead to overheat of motor without working of safety devices.												
corrosion	Corrosion of the fan may lead to mechanical damage of it. It is forbidden to use the fan if corrosion appears												
overload	Exceeding of nominal current may be caused by improper choice of fan, mechanical damage (e.g. impeller, bearing), improper electrical connection. Current value must be controlled, and if its growth is noticed, the reason need to be determined and device need to be repaired. Current value cannot exceed nominal value.												
vibration	Excessive vibration may cause mechanical damage of the fan or it mounting construction. The vibration increase can indicate bearings damage or loss of impeller balance. Vibration value need to be controlled, and if its growth is noticed, the reason need to be determined and device must be repaired. Maximum vibration value on bearings (perpendicular to motor shaft) after fan installation cannot exceed value presented in table below: <table border="1" data-bbox="603 1787 1198 1883"> <thead> <tr> <th colspan="2">rigidly mounted*</th> <th colspan="2">flexibly monted*</th> </tr> <tr> <th>peak</th> <th>r.m.s</th> <th>peak</th> <th>r.m.s.</th> </tr> </thead> <tbody> <tr> <td>6.4 mm/s</td> <td>4.5 mm/s</td> <td>8.8 mm/s</td> <td>6.3 mm/s</td> </tr> </tbody> </table> *according to ISO 14694	rigidly mounted*		flexibly monted*		peak	r.m.s	peak	r.m.s.	6.4 mm/s	4.5 mm/s	8.8 mm/s	6.3 mm/s
rigidly mounted*		flexibly monted*											
peak	r.m.s	peak	r.m.s.										
6.4 mm/s	4.5 mm/s	8.8 mm/s	6.3 mm/s										

5.2 Review and maintenance

- The set between routine checks and maintenance need to be determined by user, based on the observation of unit and specific conditions of use, in order to include specific work conditions. The set cannot be longer than introduced below
- In the case of irregularities the device must be turn off and subjected to review, maintenance and possible repairs / cleaning (when dirt occurs). Examples of reasons for device to work in emergency mode are given in Appendix C.
- Staff operating the device must be familiar with it normal working conditions. If the fan work differ from it normal working conditions it need to be turn off from work and inspected.
- Detailed information about komponents and it tightening torque is available on request.

Recommended daily review, not less frequently than once a week.:

- Device is undamaged, stable and works properly
- There are not any leaks, smoke from motor
- Device does not emit any untypical noise, and does not heat up excessively
- Device is clean (general control), corrosion does not occur (general control)
- Wires are not damaged
- there are no untypical leaks from fan
- Covers are in proper state and clean

Mmonthly review

- Fan current value is not higher than beginning value
- The values of generated vibration did not increase (according to beginning value)
- Device and covers are clean
- Device is clean, filter is not clogged.

Review once per 3 months, not less than 6 month and 3000 hours of work

- Corrosion does not occur
- Fasteners state is proper (they are properly tightened)
- Security devices are working and set properly, protection against electrical shock is effective.
- Motor insulation resistance value is correct
- Structure is complete, components are not damaged (e.g. by abrasion)

Fan review made by Venture Industries Sp. z o.o. service is recommended.





6. REPAIR, WARRANTY

Use only original spare parts and original accessories. Fan repairs need to be made by Venture Industries Sp. z o.o. service or outside, after manufacturer permission. Warrantee conditions are described in guarantee card.

7. DISMANTLING AND RECYCLING

Disconnect unit from its power supply, and dismount according to the guidelines from section 1 of this instruction. Therefore, please deposit all left-over material and packaging in their corresponding recycling containers and hand in the replaced machines to the nearest handler of this type of waste product.

Appendix - A (Product indication)

		www.venture.pl www.ventur.se www.ventur.fi www.venturdeutschland.de VENTUR TEKNISKA AB VENTUR FINLAND OY VENTUR DEUTSCHLAND GmbH			
[1]					
Motor	[2]	[3] kW	[4] A	IP	[5]
[6] V	[8] Hz	[9] rpm	Ins. class [10]		
Weight [11] kg	Temp. ambient max. [12] °C		Temp. max. [13] °C		
			[14]		
No.: [15]		Art. No.: [16]			

[1] – product full name

[2] – motor type

[3] – motor power

[4] – nominal current

[5] – motor IP class

[8] – nominal voltage

[8] – power supply frequency

[9] – nominal fan speed

[10]- motor insulation class

[11] - weight

[12] – max ambient temperature

[13] – max temperature of transported medium

[14] – information of accordance with ErP Directive (if apply)

[15] – serial number

[16] – Art. No.

Additional information indicated on the device

- arrow informing about correct direction of impeller rotation
- arrow informing about correct air flow direction
- indications related to safe use of device

Appendix B - (The device receipt form)

Before launch	Check confirmation
Type and model of fan are in accordance with the order.	
The fan is undamaged.	
There is no foreign body inside fan, and the fan is clean.	
The fan is reliably and solidly fixed in workplace.	
The fan is properly leveled	
Wires are properly tightened.	
Ambient temperature and transported medium temperature are compatible with fan nameplate	
Proper electrical protection is applied	
Grounding of fan is applied.	
Network power supply is compatible with fan power supply.	
Power supply disconnecting switch is applied.	
Personnel using the fan read and understood the operation and montage manual.	
Proper inlet and outlet covers (grids) have been applied	
After fan launch (continuous work period minimum 30 minutes)	
Readings and set of vibration measurement device has been written (they are available in future)	
Readings and set of current measurement device has been written (they are available in future)	
Value of current for each of phase does not exceed nominal one	
The vibration value is not higher than permitted.	

Appendix - C (EXAMPLES OF DEVICE FAULTY WORKING)

SYMPTOMS	POSSIBLE REASON
Excessive vibration or noise	<ul style="list-style-type: none"> •Used or damaged impeller •Fan levelled in wrong way •Dirt accumulated on impeller caused loss of balance; •Impeller loss of balance •Parts rubbing; •Damage or wear of bearings; •Damage of measurement system, that is responsible for signalization of excessive vibration. •Deformed motor shaft; •Loose of impeller fix screw, impeller is loose on motor shaft; •Loss of balance of motor impeller or damage of motor (wear/damage of bearing)
Motor overload	<ul style="list-style-type: none"> •Rubbing between fan impeller and housing; •Damage or wear of bearings; •Damage of motor windings (overheat, insulation degradation, insulation breakdown etc.); •Damage of switch or security system; •Failure of one of supply phases; •Exceeding of maximum motor speed; •Too low flow
Failed fan start-up	<ul style="list-style-type: none"> •Rubbing between fan impeller and housing or foreign body (e.g. tool left after installation); •Failure of one of supply phases; •Failure of start-up system, e.g. Y/D •Reset of security devices has not been made, wrong security device •Motor connected in wrong way or damaged •Too low supply voltage
Protective devices activation during fan work and overheating	<ul style="list-style-type: none"> •Excessive start-up time •Motor overload •Motor launching done too often (thermal protection – if applied or overheating) •Improper set of protection system e.g. in system with PTC or thermocontact sensors (if applied) •Improper cross-section of power supply wires •Lack of sufficient motor cooling eg. dirt placed on motor cooling impeller (thermal protection – if applied or overheating)
Too low flow	<ul style="list-style-type: none"> •Damage of device •Too low power supply frequency •Obstacles in ventilation installation •Damaged bearings

Appendix - D (Declaration of Manufacturer)

EU Declaration of Conformity in accordance with 2014/30/EU Directives
EC Declaration of Incorporation in accordance with 2006/42/EC Directive (Appendix II 1B)

**Manufacturer:**

Venture Industries Sp. z o.o.
ul. Mokra 27
05-092 Łomianki-Kielpin
Polska

doc. no. P1.1.12122016_EN

declares that the product described below:

Name: Centrifugal fan
Type: BN / BM / BH / BE / BL / GFB / GFS / GFS-HT / GMB / GMT / GMT-HT / GSB / GSF / GST / HBB / HBB-HT / HBB-K / HSD / HSR / HST / HST-HT / HST-K / KEF / LFA / LFB / LFS / MBA / MBB / MBB-HT / MBB-K / MBB-P / MDA / MHB / MPA / MPB / MPB-HT / MPB-K / MPR / MPT / MPT-HT / MPT-K / MRA / MRB / MSB / MSB-HT / MSB-K / MSB-P / MSBN / MSBN-HT / MSBN-K / MST / MTA / QP
Model and serial no.: all manufactured
CE marking date: 2010 / 2012 (HSD) / 2015 (GMT, GMB, BN, BM, BL, BE) - in accordance with 2014/30/EU Directive
Use/Function: transport of specified medium **after incorporation into machinery (as defined by 2006/42/WE Directive)**

complies with the requirements of:

- Machinery Directive 2006/42/EC – Annex I, item: 1.3.4, 1.5.1, 1.7.1.
- Electromagnetic Compatibility Directive 2014/30/EU

Compliance with 2014/30/EU Directive applies to the single product. When product is used with other components the installer is responsible for compliance of entire system with the provisions of 2014/30/EU Directive.

Following standards were applied (partially or full):

EN ISO 12100 EN 60034-1 EN 60204-1 EN ISO 13857

Compliance with EN ISO 13857 refers to safety devices supplied and installed in the product by the manufacturer.

Furthermore:

- Product is partly completed machinery (as defined by Directive 2006/42/EC), and it must not be put into service until the machinery in which it is incorporated has been declared in conformity with the provisions of 2006/42/EC Directive (and its amendments).
- The machinery (installation) into which the product is incorporated should particularly meet the requirements of current standards: EN ISO 12100, EN ISO 13857, EN 349+A1, EN ISO 13850, EN 60204-1.
- Unit complies with Regulation (EU) No 327/2011 implementing Directive 2009/125/EC with regard to ecodesign requirements for fans driven by motors with an electric input power between 125 W and 500 kW.
- In accordance with 2006/42/EC Directive requirements: The technical documentation for above mentioned product has been prepared in accordance with Directive 2006/42/EC, Annex VII, Part B, and is located in the manufacturer office: Lotnicza 21A, 86-300, Grudziądz, Poland. The person authorized to comply the relevant technical documentation: Zbigniew Kosmecki (Lotnicza 21A, 86-300, Grudziądz, Poland). Relevant information about the product will be provided in electronic or paper form in response to a reasonable request of national authorities.
- Quality system is in accordance with ISO 9001:2008.

Wojciech Stawski
Managing Director



Date: 12.12.2016
Kielpin

Appendix - E (Schematic diagram of the fan)

General description (simplified)

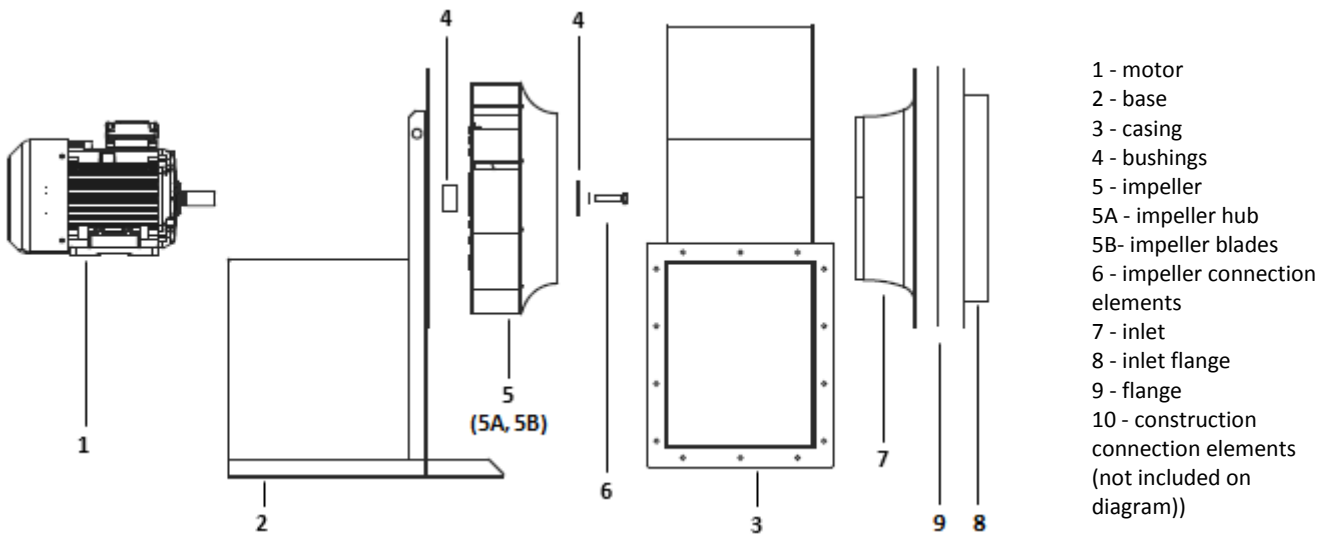
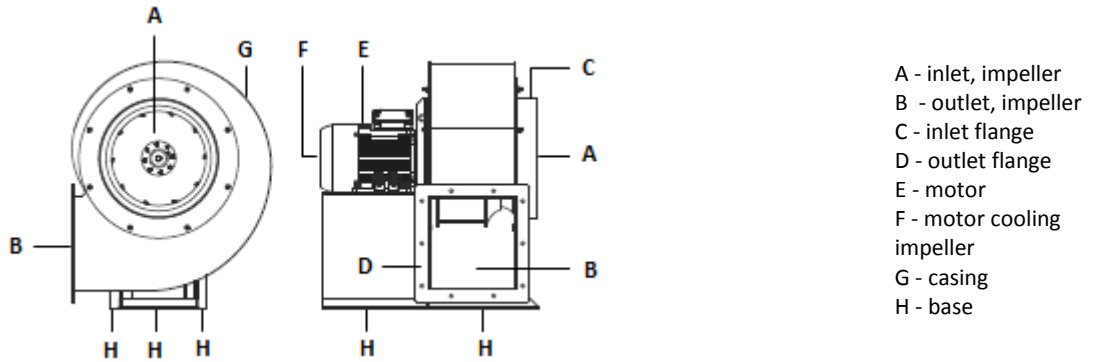

Casing (3), base (2), inlet flange (8), flange (9) are made from carbon steel. Inlet (7) is made from aluminum / carbon steel. Impeller hub (5A) is made from carbon steel / aluminum / aluminum alloy, with use of connection elements made from galvanized steel and/or stainless steel. Impeller blades (5B) are made from carbon steel / aluminum. Bushings (4) are made from steel / stainless steel. Connection elements (6, 10) are made from steel / stainless steel. For sealing - sealing paste and sealing tapes (e.g. EPDM) has been used, selected elements have been painted. Full list of components and materials used in fan can be provided on reasonable request.